

# RE 13 Ø13 mm, Graphite Brushes, 1.5 Watt

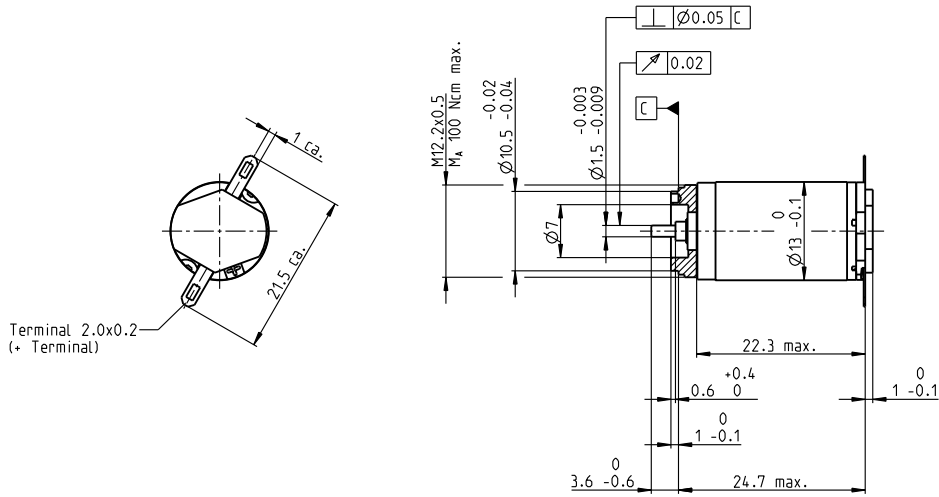

M 1:1

- Stock program
- Standard program
- Special program (on request)

## Part Numbers

Motor Data	118536	118537	118538	118539	118540	118541	118542	118543	118544	118545	118546	118547	118548	118549	118550	
<b>Values at nominal voltage</b>																
1 Nominal voltage	V	1.2	1.5	2.4	3	3.6	4.2	4.8	6	7.2	9	12	12	15	18	20
2 No load speed	rpm	13300	13300	13700	13200	13000	13300	12300	12700	12300	12300	13300	12300	13100	14000	13300
3 No load current	mA	482	394	259	197	159	140	111	92.5	73.7	59.2	49.2	44.7	38.9	35.1	29.7
4 Nominal speed	rpm	12600	11800	10600	8520	7790	8260	7130	7480	7010	7000	8040	6940	7870	8890	8020
5 Nominal torque (max. continuous torque)	mNm	0.194	0.329	0.719	1.06	1.23	1.27	1.28	1.25	1.26	1.25	1.21	1.22	1.21	1.2	1.19
6 Nominal current (max. continuous current)	A	0.72	0.72	0.72	0.72	0.659	0.588	0.481	0.39	0.316	0.252	0.199	0.186	0.157	0.139	0.119
7 Stall torque	mNm	4.07	3.25	3.33	3.19	3.3	3.56	3.26	3.25	3.16	3.12	3.28	3.01	3.23	3.51	3.22
8 Stall current	A	5.2	3.4	2.26	1.67	1.41	1.32	0.989	0.814	0.639	0.506	0.429	0.368	0.335	0.321	0.254
9 Max. efficiency	%	49	44	45	44	45	46	45	45	44	44	45	43	44	46	44
<b>Characteristics</b>																
10 Terminal resistance	Ω	0.231	0.441	1.06	1.8	2.56	3.18	4.85	7.37	11.3	17.8	28	32.6	44.8	56.1	78.8
11 Terminal inductance	mH	0.006	0.009	0.022	0.036	0.054	0.072	0.108	0.158	0.243	0.377	0.579	0.661	0.921	1.19	1.59
12 Torque constant	mNm/A	0.782	0.956	1.48	1.91	2.35	2.69	3.3	4	4.95	6.17	7.64	8.17	9.64	10.9	12.7
13 Speed constant	rpm/V	12200	9990	6470	5000	4070	3550	2890	2390	1930	1550	1250	1170	990	872	753
14 Speed / torque gradient	rpm/mNm	3600	4610	4660	4700	4440	4190	4250	4410	4390	4460	4570	4660	4600	4470	4680
15 Mechanical time constant	ms	13.5	14	14.1	14.2	14.1	14	14	14.1	14.2	14.2	14.3	14.3	14.3	14.2	14.4
16 Rotor inertia	gcm <sup>2</sup>	0.358	0.291	0.29	0.288	0.303	0.318	0.315	0.306	0.308	0.304	0.3	0.293	0.297	0.303	0.294

Specifications	
<b>Thermal data</b>	
17 Thermal resistance housing-ambient	46 K/W
18 Thermal resistance winding-housing	14 K/W
19 Thermal time constant winding	5.38 s
20 Thermal time constant motor	231 s
21 Ambient temperature	-20...+85°C
22 Max. winding temperature	+125°C
<b>Mechanical data (sleeve bearings)</b>	
23 Max. speed	16000 rpm
24 Axial play	0.05 - 0.15 mm
25 Radial play	0.014 mm
26 Max. axial load (dynamic)	0.8 N
27 Max. force for press fits (static)	15 N
28 Max. radial load, 5 mm from flange	1.4 N
<b>Other specifications</b>	
29 Number of pole pairs	1
30 Number of commutator segments	7
31 Weight of motor	17 g

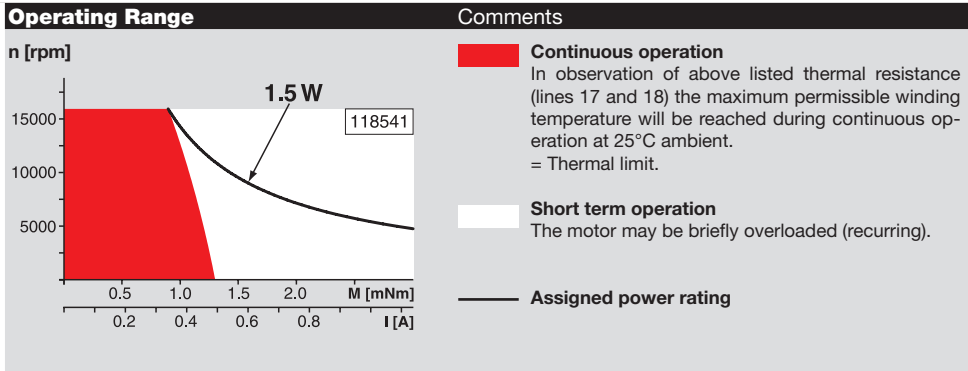

**maxon Modular System**

**Planetary Gearhead**  
Ø13 mm  
0.05 - 0.15 Nm  
Page 316

**Planetary Gearhead**  
Ø13 mm  
0.2 - 0.35 Nm  
Page 317

**Recommended Electronics:**  
Notes Page 24  
ESCON Module 24/2 416  
ESCON 36/2 DC 416

Overview on page 20-27